

- | | |
|---|------------------------------|
| 1. Power cable entry 3x1,5
(230Vx1-50Hz) | 3. Water loading pipe Ø3/4"G |
| 2. Water drain pipe Ø30 Hmax=6 cm. | 4. Equipotential |
| | 5. Dosing pumps entry |

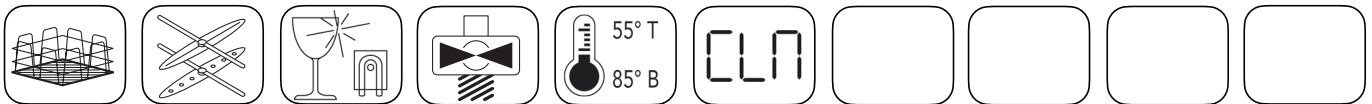

- Single wall.
- Tank with rounded corners.
- TOUCH control panel with 5 preset wash cycle times.
- Magnetic microswitch to cut out operation of the appliance when door is opened.
- Useful washing height 31,5 cm, dish Ø32 (Ø35 cm with basket M251-M252).
- Square basket 50x50 cm. (supplied with 1 plate basket, 1 flat basket, 2 cutlery holders).
- Independent lower/upper washing and rinsing arms.
- Washing cycle time 60-90-120-150-180 seconds (capacity 360÷1080 pz/h).
- Displays show the boiler and tank temperature.
- Countdown of the washing cycle underway in minutes and seconds.
- Standard built-in rinse-aid pump.
- Self-cleaning cycle (CLN).
- Built-in insulated boiler made in AISI 304L stainless steel.
- Boiler and tank heating through thermostatically protected armoured heating elements (in exchange).
- Tank capacity lt. 26 and boiler capacity lt. 8.
- Water consumption per cycle lt. 3,8 - Water pressure input ATE 1,5-3,0 - Max temperature of inlet water 50°C.
- Tank heating element kW 2,5 - Boiler heating element kW 3,0.
- Washing pump power Hp 0,75.
- Noise level at 1 mt. < 70 dbA.
- Total power kW 3,55.

Note

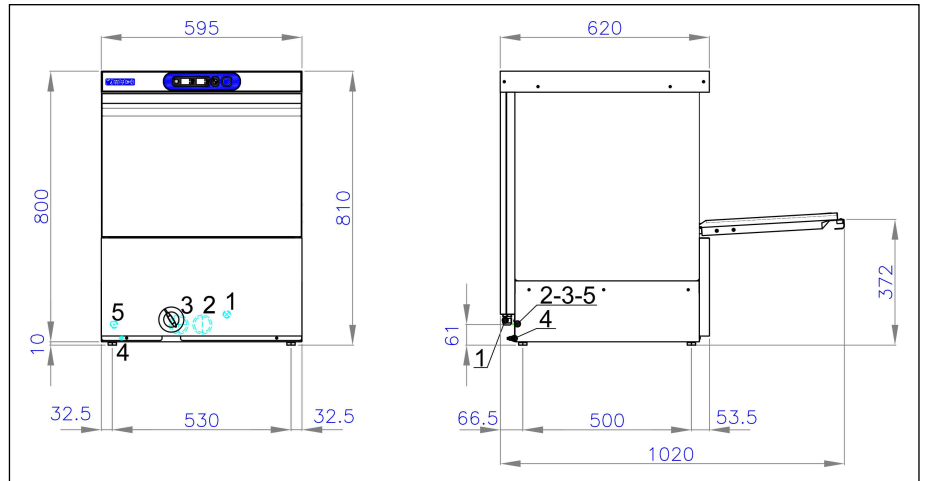

- | | |
|---|-------------------------------|
| 1. Power cable entry 3x1,5
(230Vx1-50Hz) | 3. Water loading pipe Ø3/4" G |
| 2. Water drain pipe Ø30 Hmax=6 cm. | 4. Equipotential |
| | 5. Dosing pumps entry |

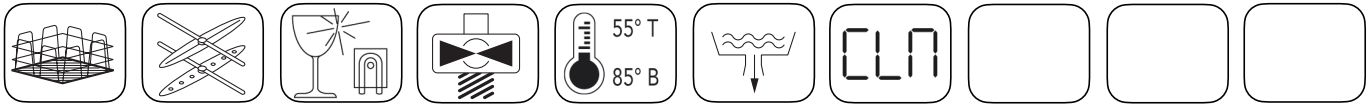

- Single wall.
- Tank with rounded corners.
- TOUCH control panel with 5 preset wash cycle times.
- Magnetic microswitch to cut out operation of the appliance when door is opened.
- Useful washing height 31,5 cm, dish Ø32 (Ø35 cm with basket M251-M252).
- Square basket 50x50 cm. (supplied with 1 plate basket, 1 flat basket, 2 cutlery holders).
- Independent lower/upper washing and rinsing arms.
- Washing cycle time 60-90-120-150-180 seconds (capacity 360÷1080 pz/h).
- Displays show the boiler and tank temperature.
- Countdown of the washing cycle underway in minutes and seconds.
- Standard built-in rinse-aid pump.
- Self-cleaning cycle (CLN).
- Built-in insulated boiler made in AISI 304L stainless steel.
- Boiler and tank heating through thermostatically protected armoured heating elements (in exchange).
- Included drain pump.
- Tank capacity lt. 26 and boiler capacity lt. 8.
- Water consumption per cycle lt. 3,8 - Water pressure input ATE 1,5-3,0 - Max temperature of inlet water 50°C.
- Tank heating element kW 2,5 - Boiler heating element kW 3,0.
- Washing pump power Hp 0,75.
- Noise level at 1 mt. < 70 dbA.
- Total power kW 3,55.

Note

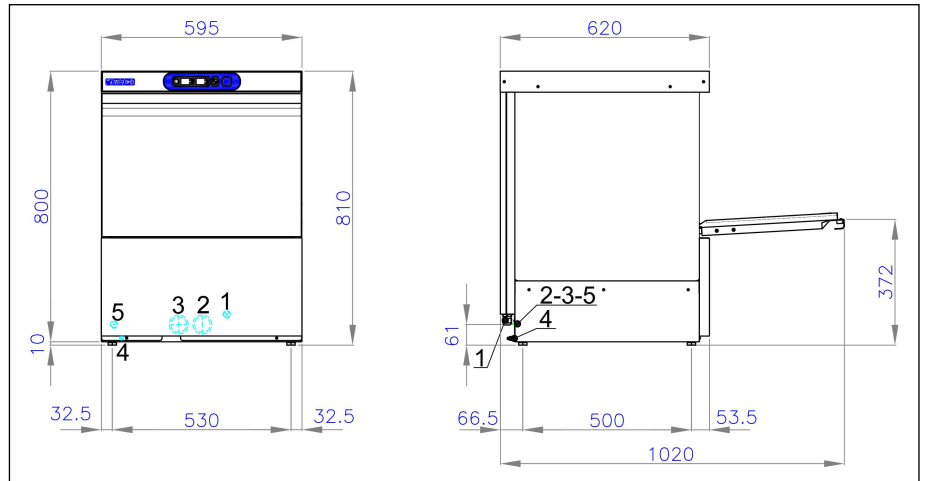

- | | |
|--|-------------------------------|
| 1. Power cable entry 5x2,5 (400Vx3N/
230Vx3N/230Vx1-50Hz) | 3. Water loading pipe Ø3/4" G |
| 2. Water drain pipe Ø30 Hmax=6 cm. | 4. Equipotential |
| | 5. Dosing pumps entry |

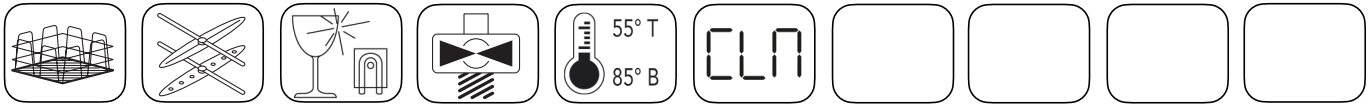

- Single wall.
- Tank with rounded corners.
- TOUCH control panel with 5 preset wash cycle times.
- Magnetic microswitch to cut out operation of the appliance when door is opened.
- Useful washing height 31,5 cm, dish Ø32 (Ø35 cm with basket M251-M252).
- Square basket 50x50 cm. (supplied with 1 plate basket, 1 flat basket, 2 cutlery holders).
- Independent lower/upper glasswashing and rinsing arms.
- Washing cycle time 60-90-120-150-180 seconds (capacity 360÷1080 pz/h).
- Displays show the boiler and tank temperature.
- Countdown of the washing cycle underway in minutes and seconds.
- Standard built-in rinse-aid pump.
- Self-cleaning cycle (CLN).
- Built-in insulated boiler made in AISI 304L stainless steel.
- Boiler and tank heating through thermostatically protected armoured heating elements (in exchange).
- Tank capacity lt. 26 and boiler capacity lt. 8.
- Water consumption per cycle lt. 3,8 - Water pressure input ATE 1,5-3,0 - Max temperature of inlet water 50°C.
- Tank heating element kW 2,5 - Boiler heating element kW 4,5 (Cold water input kW 6,0).
- Washing pump power Hp 0,75.
- Noise level at 1 mt. < 70 dbA.
- Total power kW 5,05.

Note

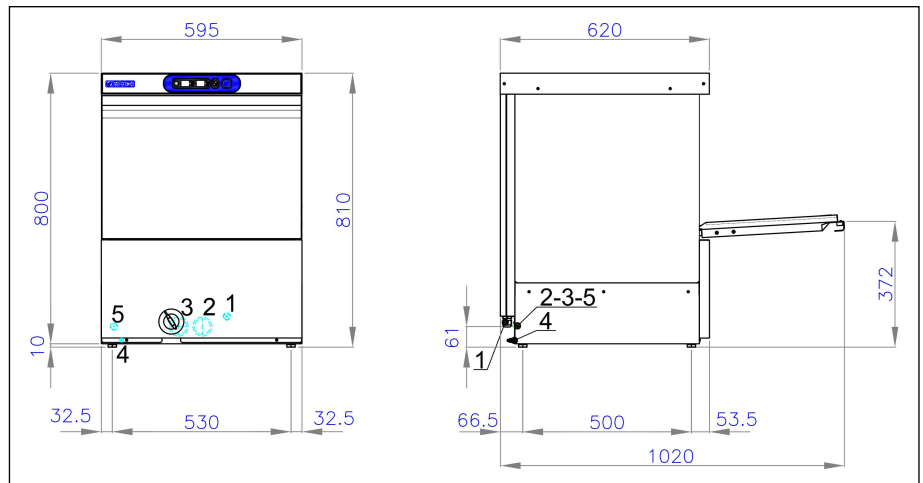

- | | |
|--|-------------------------------|
| 1. Power cable entry 5x2,5 (400Vx3N/
230Vx3N/230Vx1-50Hz) | 3. Water loading pipe Ø3/4" G |
| 2. Water drain pipe Ø30 Hmax=6 cm. | 4. Equipotential |
| | 5. Dosing pumps entry |

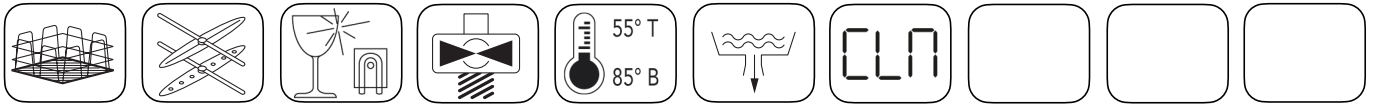

- Single wall.
- Tank with rounded corners.
- TOUCH control panel with 5 preset wash cycle times.
- Magnetic microswitch to cut out operation of the appliance when door is opened.
- Useful washing height 31,5 cm, dish Ø32 (Ø35 cm with basket M251-M252).
- Square basket 50x50 cm. (supplied with 1 plate basket, 1 flat basket, 2 cutlery holders).
- Independent lower/upper washing and rinsing arms.
- Washing cycle time 60-90-120-150-180 seconds (capacity 360÷1080 pz/h).
- Displays show the boiler and tank temperature.
- Countdown of the washing cycle underway in minutes and seconds.
- Standard built-in rinse-aid pump.
- Self-cleaning cycle (CLN).
- Built-in insulated boiler made in AISI 304L stainless steel.
- Boiler and tank heating through thermostatically protected armoured heating elements (in exchange).
- Included drain pump.
- Tank capacity lt. 26 and boiler capacity lt. 8.
- Water consumption per cycle lt. 3,8 - Water pressure input ATE 1,5-3,0 - Max temperature of inlet water 50°C.
- Tank heating element kW 2,5 - Boiler heating element kW 4,5 (Cold water input kW 6,0).
- Washing pump power Hp 0,75.
- Noise level at 1 mt. < 70 dbA.
- Total power kW 5,05.

Note

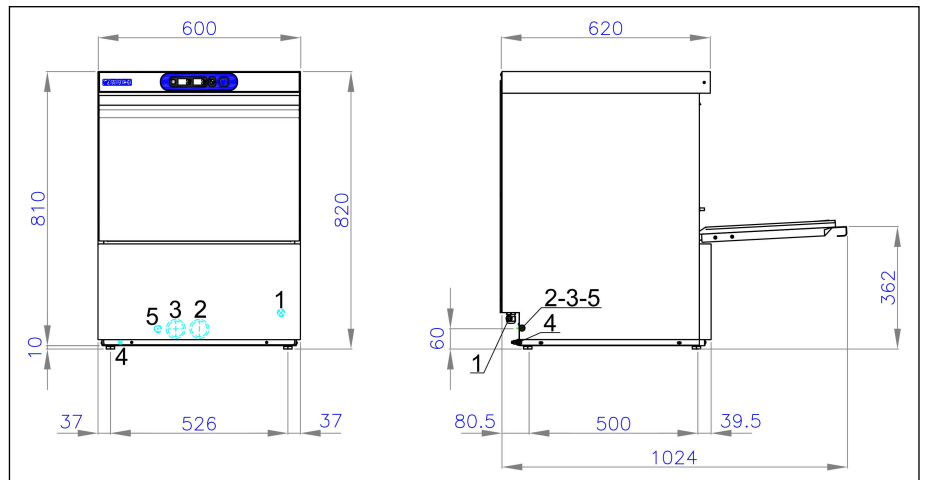

- | | |
|--|------------------------------|
| 1. Power cable entry 3x1,5 (230Vx1-50Hz) | 3. Water loading pipe Ø3/4"G |
| 2. Water drain pipe Ø30 Hmax=6 cm. | 4. Equipotential |
| | 5. Dosing pumps entry |

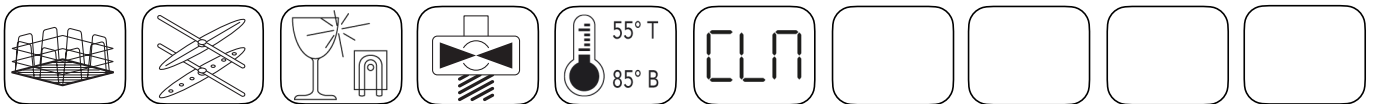

- Double wall.
- Tank with rounded corners.
- Full-width wash tank filters.
- TOUCH control panel with 5 preset wash cycle times.
- Magnetic microswitch to cut out operation of the appliance when door is opened.
- Useful washing height 33,5 cm, dish Ø36 (Ø39 cm with basket M251-M252).
- Square basket 50x50 cm. (supplied with 1 plate basket, 1 flat basket, 2 cutlery holders).
- Independent lower/upper washing and rinsing arms.
- Washing cycle time 60-90-120-150-180 seconds (capacity 360÷1080 pz/h).
- Displays show the boiler and tank temperature.
- Countdown of the washing cycle underway in minutes and seconds.
- Standard built-in rinse-aid pump.
- Self-cleaning cycle (CLN).
- Built-in insulated boiler made in AISI 304L stainless steel.
- Boiler and tank heating through thermostatically protected armoured heating elements (in exchange).
- Tank capacity lt. 16 and boiler capacity lt. 8.
- Water consumption per cycle lt. 3,5 - Water pressure input ATE 1,5-3,0 - Max temperature of inlet water 50°C.
- Tank heating element kW 2,5 - Boiler heating element kW 3,0.
- Washing pump power Hp 0,75.
- Noise level at 1 mt. < 70 dbA.
- Total power kW 3,55.

Note

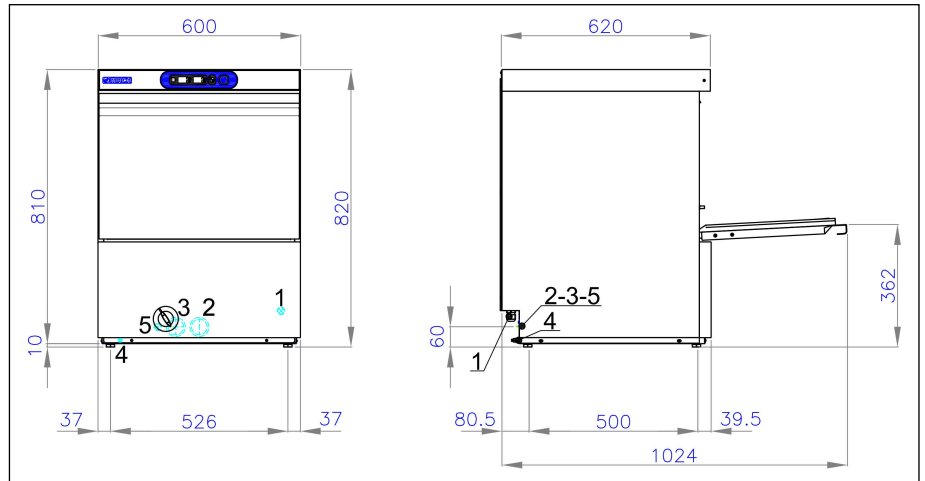

- | | |
|--|-------------------------------|
| 1. Power cable entry 3x1,5 (230Vx1-50Hz) | 3. Water loading pipe Ø3/4" G |
| 2. Water drain pipe Ø30 Hmax=6 cm. | 4. Equipotential |
| | 5. Dosing pumps entry |

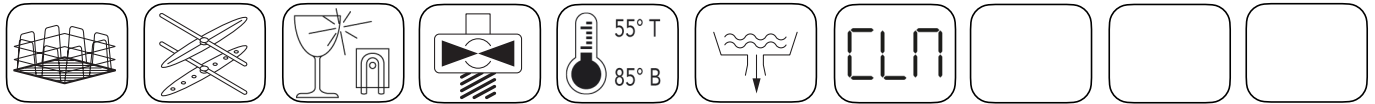

- Double wall.
- Tank with rounded corners.
- Full-width wash tank filters.
- TOUCH control panel with 5 preset wash cycle times.
- Magnetic microswitch to cut out operation of the appliance when door is opened.
- Useful washing height 33,5 cm, dish Ø36 (Ø39 cm with basket M251-M252).
- Square basket 50x50 cm. (supplied with 1 plate basket, 1 flat basket, 2 cutlery holders).
- Independent lower/upper washing and rinsing arms.
- Washing cycle time 60-90-120-150-180 seconds (capacity 360÷1080 pz/h).
- Displays show the boiler and tank temperature.
- Countdown of the washing cycle underway in minutes and seconds.
- Standard built-in rinse-aid pump.
- Self-cleaning cycle (CLN).
- Built-in insulated boiler made in AISI 304L stainless steel.
- Boiler and tank heating through thermostatically protected armoured heating elements (in exchange).
- Included drain pump.
- Tank capacity lt. 16 and boiler capacity lt. 8.
- Water consumption per cycle lt. 3,5 - Water pressure input ATE 1,5-3,0 - Max temperature of inlet water 50°C.
- Tank heating element kW 2,5 - Boiler heating element kW 3,0.
- Washing pump power Hp 0,75.
- Noise level at 1 mt. < 70 dbA.
- Total power kW 3,55.

Note

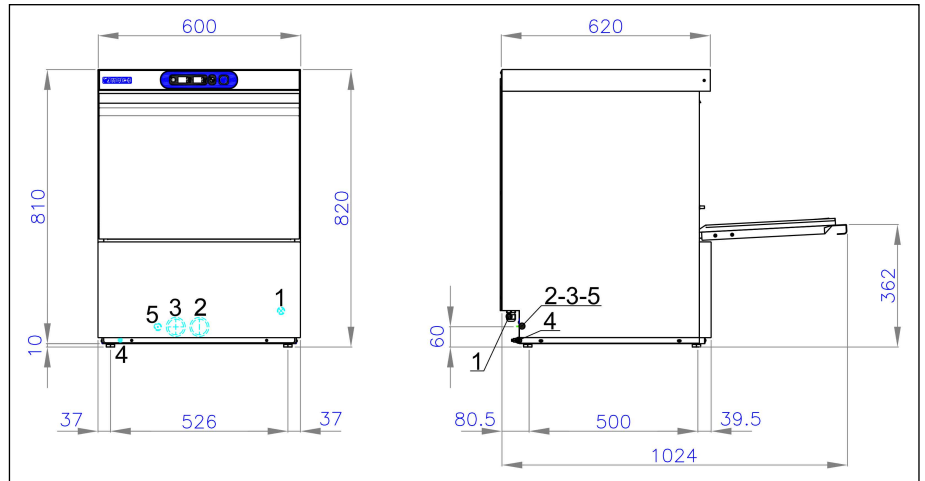

- | | |
|--|-------------------------------|
| 1. Power cable entry 5x2,5 (400Vx3N/
230Vx3N/230Vx1-50Hz) | 3. Water loading pipe Ø3/4" G |
| 2. Water drain pipe Ø30 Hmax=6 cm. | 4. Equipotential |
| | 5. Dosing pumps entry |

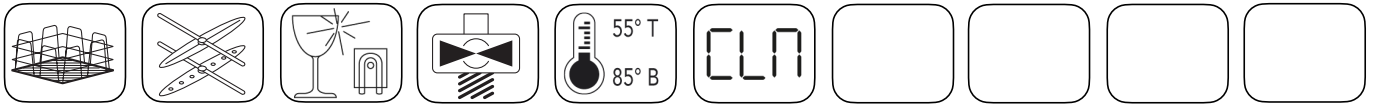

- Double wall.
- Tank with rounded corners.
- Full-width wash tank filters.
- TOUCH control panel with 5 preset wash cycle times.
- Magnetic microswitch to cut out operation of the appliance when door is opened.
- Useful washing height 33,5 cm, dish Ø36 (Ø39 cm with basket M251-M252).
- Square basket 50x50 cm. (supplied with 1 plate basket, 1 flat basket, 2 cutlery holders).
- Independent lower/upper washing and rinsing arms.
- Washing cycle time 60-90-120-150-180 seconds (capacity 360÷1080 pz/h).
- Displays show the boiler and tank temperature.
- Countdown of the washing cycle underway in minutes and seconds.
- Standard built-in rinse-aid pump.
- Self-cleaning cycle (CLN).
- Built-in insulated boiler made in AISI 304L stainless steel.
- Boiler and tank heating through thermostatically protected armoured heating elements (in exchange).
- Tank capacity lt. 16 and boiler capacity lt. 8.
- Water consumption per cycle lt. 3,5 - Water pressure input ATE 1,5-3,0 - Max temperature of inlet water 50°C.
- Tank heating element kW 2,5 - Boiler heating element kW 4,5 (Cold water input kW 6,0).
- Washing pump power Hp 0,75.
- Noise level at 1 mt. < 70 dbA.
- Total power kW 5,05.

Note

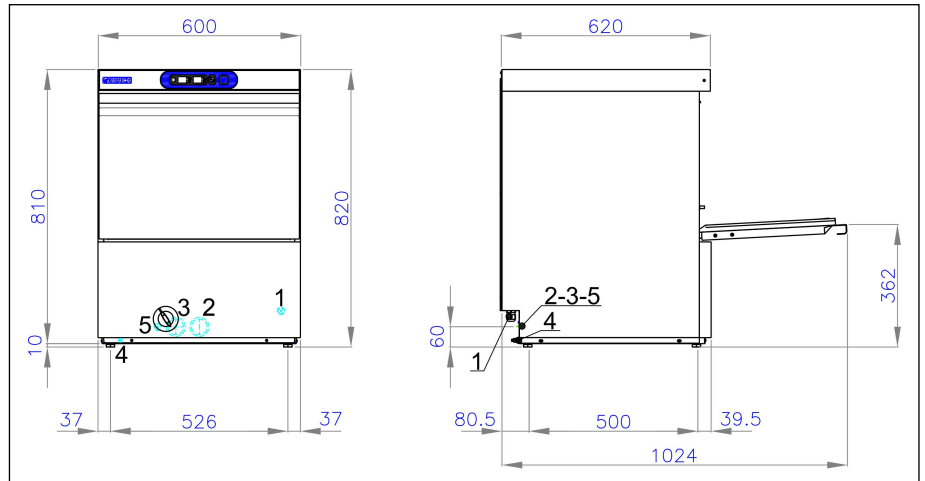

- | | |
|--|-------------------------------|
| 1. Power cable entry 5x2,5 (400Vx3N/
230Vx3N/230Vx1-50Hz) | 3. Water loading pipe Ø3/4" G |
| 2. Water drain pipe Ø30 Hmax=6 cm. | 4. Equipotential |
| | 5. Dosing pumps entry |

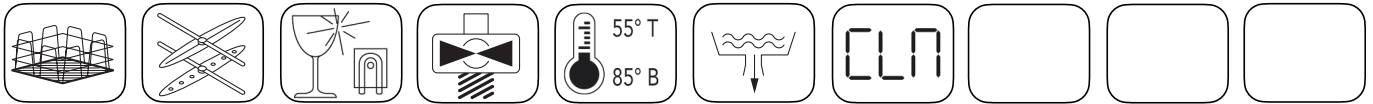

- Double wall.
- Tank with rounded corners.
- Full-width wash tank filters.
- TOUCH control panel with 5 preset wash cycle times.
- Magnetic microswitch to cut out operation of the appliance when door is opened.
- Useful washing height 33,5 cm, dish Ø36 (Ø39 cm with basket M251-M252).
- Square basket 50x50 cm. (supplied with 1 plate basket, 1 flat basket, 2 cutlery holders).
- Independent lower/upper washing and rinsing arms.
- Washing cycle time 60-90-120-150-180 seconds (capacity 360÷1080 pz/h).
- Displays show the boiler and tank temperature.
- Countdown of the washing cycle underway in minutes and seconds.
- Standard built-in rinse-aid pump.
- Self-cleaning cycle (CLN).
- Built-in insulated boiler made in AISI 304L stainless steel.
- Boiler and tank heating through thermostatically protected armoured heating elements (in exchange).
- Included drain pump.
- Tank capacity lt. 16 and boiler capacity lt. 8.
- Water consumption per cycle lt. 3,5 - Water pressure input ATE 1,5-3,0 - Max temperature of inlet water 50°C.
- Tank heating element kW 2,5 - Boiler heating element kW 4,5 (Cold water input kW 6,0).
- Washing pump power Hp 0,75.
- Noise level at 1 mt. < 70 dbA.
- Total power kW 5,05.

Note

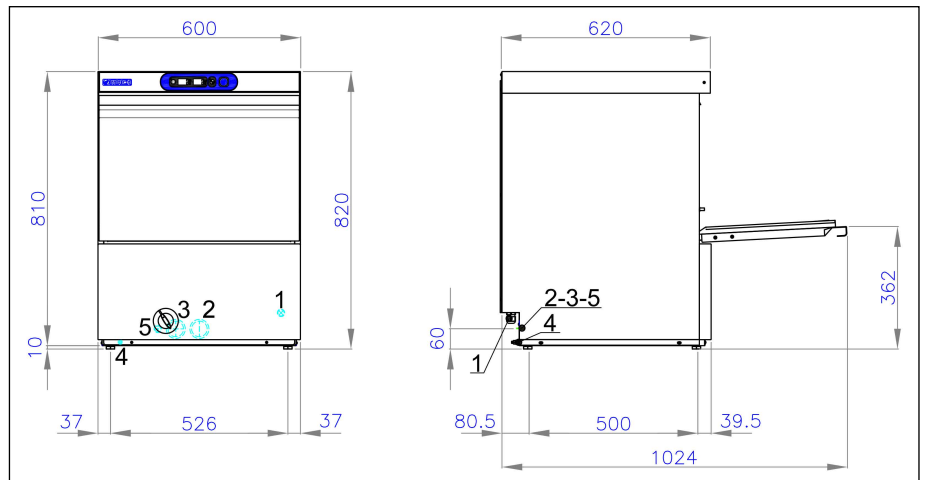

- | | |
|--|-------------------------------|
| 1. Power cable entry 5x2,5 (400Vx3N/
230Vx3N/230Vx1-50Hz) | 3. Water loading pipe Ø3/4" G |
| 2. Water drain pipe Ø30 Hmax=6 cm. | 4. Equipotential |
| | 5. Dosing pumps entry |

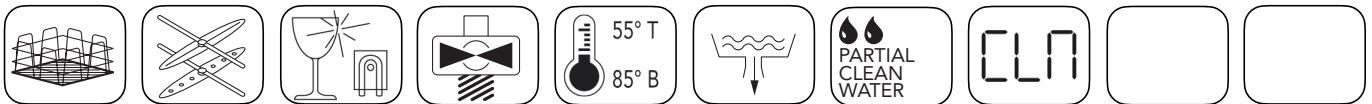

- Double wall.
- Tank with rounded corners.
- Full-width wash tank filters.
- TOUCH control panel with 5 preset wash cycle times.
- Magnetic microswitch to cut out operation of the appliance when door is opened.
- Useful washing height 33,5 cm, dish Ø36 (Ø39 cm with basket M251-M252).
- Square basket 50x50 cm. (supplied with 1 plate basket, 1 flat basket, 2 cutlery holders).
- Independent lower/upper washing and rinsing arms.
- Washing cycle time 90-120-150-180-210 seconds (capacity 306÷720 pz/h).
- Displays show the boiler and tank temperature.
- Countdown of the washing cycle underway in minutes and seconds.
- Standard built-in rinse-aid pump.
- Self-cleaning cycle (CLN).
- Built-in insulated boiler made in AISI 304L stainless steel.
- Boiler and tank heating through thermostatically protected armoured heating elements (in exchange).
- Included drain pump.
- Partial water change each cycle - automatic drain of approx. 3,5 litres of (dirty) water between wash and rinse phase.
- Tank capacity lt. 16 and boiler capacity lt. 8.
- Water consumption per cycle lt. 3,5 - Water pressure input ATE 1,5-3,0 - Max temperature of inlet water 50°C.
- Tank heating element kW 2,5 - Boiler heating element kW 4,5 (Cold water input kW 6,0).
- Washing pump power Hp 0,75.
- Noise level at 1 mt. < 70 dbA.
- Total power kW 5,05.

Note

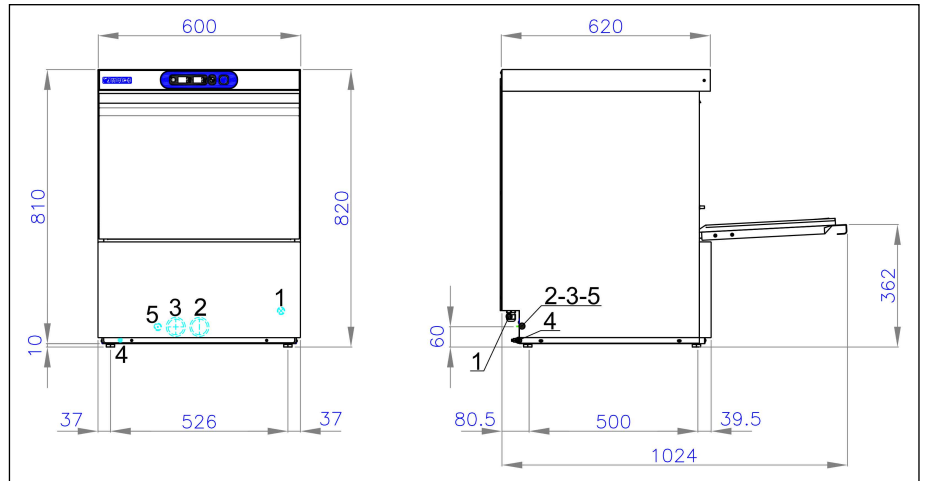

- | | |
|--|-------------------------------|
| 1. Power cable entry 5x2,5 (400Vx3N/
230Vx3N/230Vx1-50Hz) | 3. Water loading pipe Ø3/4" G |
| 2. Water drain pipe Ø30 Hmax=6 cm. | 4. Equipotential |
| | 5. Dosing pumps entry |

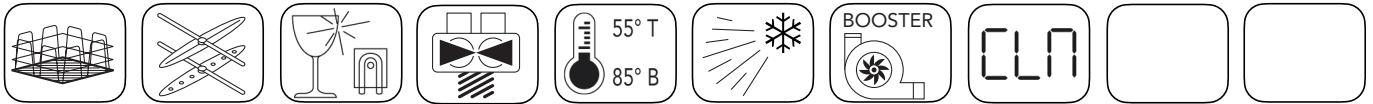

- Double wall.
- Tank with rounded corners.
- Full-width wash tank filters.
- TOUCH control panel with 5 preset wash cycle times.
- Magnetic microswitch to cut out operation of the appliance when door is opened.
- Useful washing height 33,5 cm, dish Ø36 (Ø39 cm with basket M251-M252).
- Square basket 50x50 cm. (supplied with 1 plate basket, 1 flat basket, 2 cutlery holders).
- Independent lower/upper washing and rinsing arms.
- Timed manual cold rinse.
- Washing cycle time 60-90-120-150-180 seconds (capacity 360÷1080 pz/h).
- Displays show the boiler and tank temperature.
- Countdown of the washing cycle underway in minutes and seconds.
- Standard built-in rinse-aid pump.
- Self-cleaning cycle (CLN).
- Booster pump and built-in insulated atmospheric rinse tank made in AISI 304L stainless steel.
- Boiler and tank heating through thermostatically protected armoured heating elements (in exchange).
- Tank capacity lt. 16 and boiler capacity lt. 8.
- Water consumption per cycle lt. 3,5 - Water pressure input ATE 1,5-3,0 - Max temperature of inlet water 50°C.
- Tank heating element kW 2,5 - Boiler heating element kW 4,5 (Cold water input kW 6,0).
- Washing pump power Hp 0,75.
- Booster pump power kW 0,30.
- Noise level at 1 mt. < 70 dbA.
- Total power kW 5,05.

Note

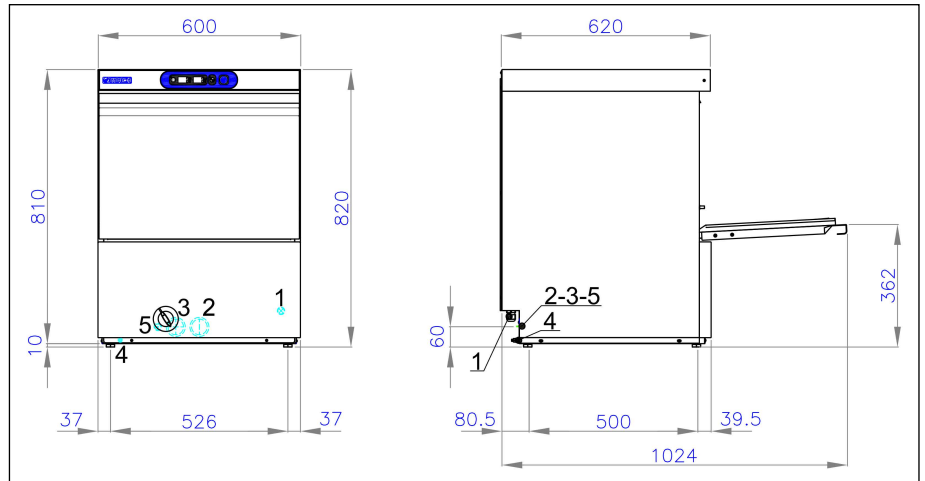

- | | |
|--|-------------------------------|
| 1. Power cable entry 5x2,5 (400Vx3N/
230Vx3N/230Vx1-50Hz) | 3. Water loading pipe Ø3/4" G |
| 2. Water drain pipe Ø30 Hmax=6 cm. | 4. Equipotential |
| | 5. Dosing pumps entry |

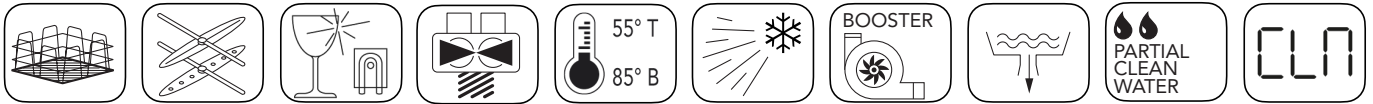

- Double wall.
- Tank with rounded corners.
- Full-width wash tank filters.
- TOUCH control panel with 5 preset wash cycle times.
- Magnetic microswitch to cut out operation of the appliance when door is opened.
- Useful washing height 33,5 cm, dish Ø36 (Ø39 cm with basket M251-M252).
- Square basket 50x50 cm. (supplied with 1 plate basket, 1 flat basket, 2 cutlery holders).
- Independent lower/upper washing and rinsing arms.
- Timed manual cold rinse.
- Washing cycle time 90-120-150-180-210 seconds (capacity 306÷720 pz/h).
- Displays show the boiler and tank temperature.
- Countdown of the washing cycle underway in minutes and seconds.
- Standard built-in rinse-aid pump.
- Self-cleaning cycle (CLN).
- Booster pump and built-in insulated atmospheric rinse tank made in AISI 304L stainless steel.
- Boiler and tank heating through thermostatically protected armoured heating elements (in exchange).
- Included drain pump.
- Partial water change each cycle - automatic drain of approx. 3,5 litres of (dirty) water between wash and rinse phase.
- Tank capacity lt. 16 and boiler capacity lt. 8.
- Water consumption per cycle lt. 3,8 - Water pressure input ATE 1,5-3,0 - Max temperature of inlet water 50°C.
- Tank heating element kW 2,5 - Boiler heating element kW 4,5 (Cold water input kW 6,0).
- Washing pump power Hp 0,75.
- Booster pump power kW 0,30.
- Noise level at 1 mt. < 70 dbA.
- Total power kW 5,05.

Note

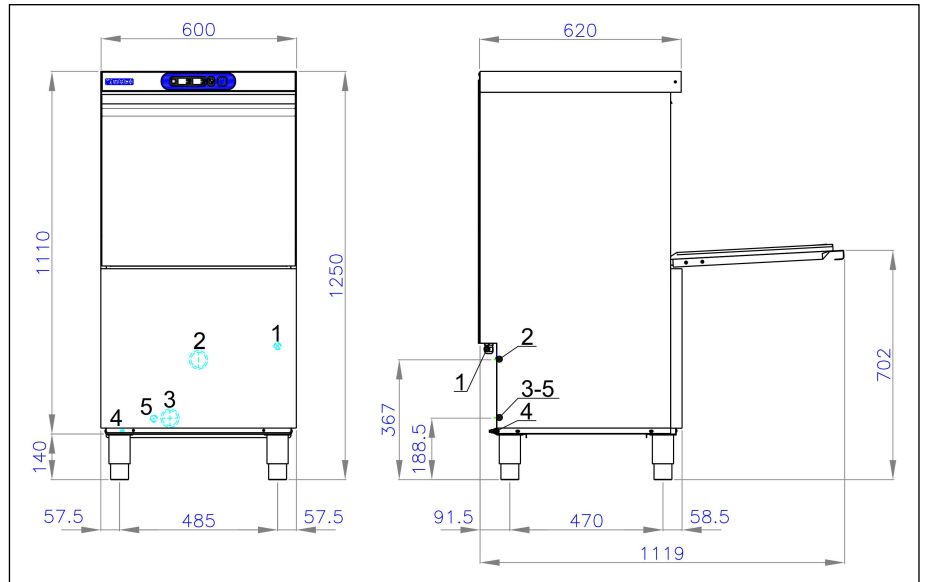

- | | |
|--|------------------------------|
| 1. Power cable entry 5x2,5 (400Vx3N/
230Vx3N/230Vx1-50Hz) | 3. Water loading pipe Ø3/4"G |
| 2. Water drain pipe Ø30 Hmax=33cm | 4. Equipotential |
| | 5. Dosing pumps entry |

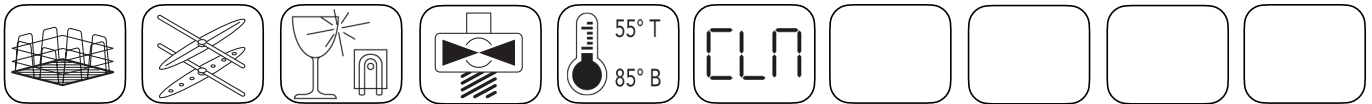

- Double wall.
- Tank with rounded corners.
- Full-width wash tank filters.
- TOUCH control panel with 5 preset wash cycle times.
- Magnetic microswitch to cut out operation of the appliance when door is opened.
- Useful washing height 41 cm, 53x37 cm tray.
- Square basket 50x50 cm. (supplied with 1 plate basket, 1 flat basket, 2 cutlery holders).
- Independent lower/upper washing and rinsing arms.
- Washing cycle time 60-90-120-150-180 seconds (capacity 360-1080 pz/h).
- Displays show the boiler and tank temperature.
- Countdown of the washing cycle underway in minutes and seconds.
- Standard built-in rinse-aid pump.
- Self-cleaning cycle (CLN).
- Built-in insulated boiler made in AISI 304L stainless steel.
- Boiler and tank heating through thermostatically protected armoured heating elements (in exchange).
- Tank capacity lt. 16 and boiler capacity lt. 8.
- Water consumption per cycle lt. 3,5 - Water pressure input ATE 1,5-3,0 - Max temperature of inlet water 50°C.
- Tank heating element kW 2,5 - Boiler heating element kW 6,0 (Cold water input kW 9,0).
- Washing pump power Hp 1.
- Noise level at 1 mt. < 70 dbA.
- Total power kW 6,74.

Note

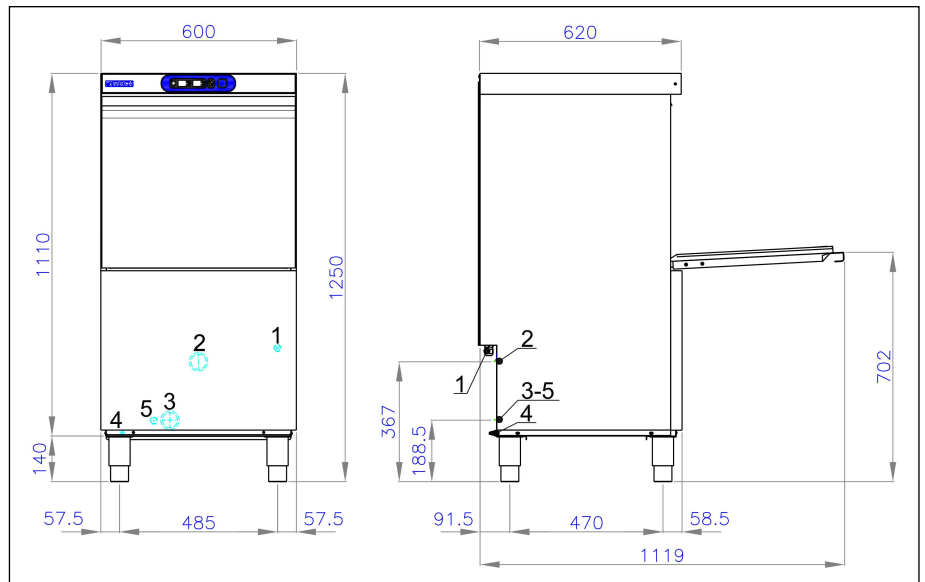

- | | |
|--|-------------------------------|
| 1. Power cable entry 5x2,5 (400Vx3N/230Vx3N/230Vx1-50Hz) | 3. Water loading pipe Ø3/4" G |
| 2. Water drain pipe Ø30 Hmax=33cm | 4. Equipotential |
| | 5. Dosing pumps entry |

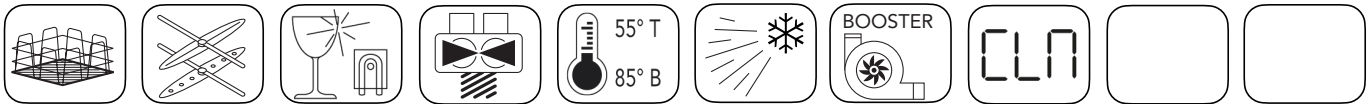

- Double wall.
- Tank with rounded corners.
- Full-width wash tank filters.
- TOUCH control panel with 5 preset wash cycle times.
- Magnetic microswitch to cut out operation of the appliance when door is opened.
- Useful washing height 41 cm, 53x37 cm tray.
- Square basket 50x50 cm. (supplied with 1 plate basket, 1 flat basket, 2 cutlery holders).
- Independent lower/upper washing and rinsing arms.
- Timed manual cold rinse.
- Washing cycle time 60-90-120-150-180 seconds (capacity 360-1080 pz/h).
- Displays show the boiler and tank temperature.
- Countdown of the washing cycle underway in minutes and seconds.
- Standard built-in rinse-aid pump.
- Self-cleaning cycle (CLN).
- Booster pump and built-in insulated atmospheric rinse tank made in AISI 304L stainless steel.
- Boiler and tank heating through thermostatically protected armoured heating elements (in exchange).
- Tank capacity lt. 16 and boiler capacity lt. 8.
- Water consumption per cycle lt. 3,5 - Water pressure input ATE 1,5-3,0 - Max temperature of inlet water 50°C.
- Tank heating element kW 2,5 - Boiler heating element kW 6,0 (Cold water input kW 9,0).
- Washing pump power Hp 1.
- Booster pump power kW 0,30.
- Noise level at 1 mt. < 70 dbA.
- Total power kW 6,74.

Note

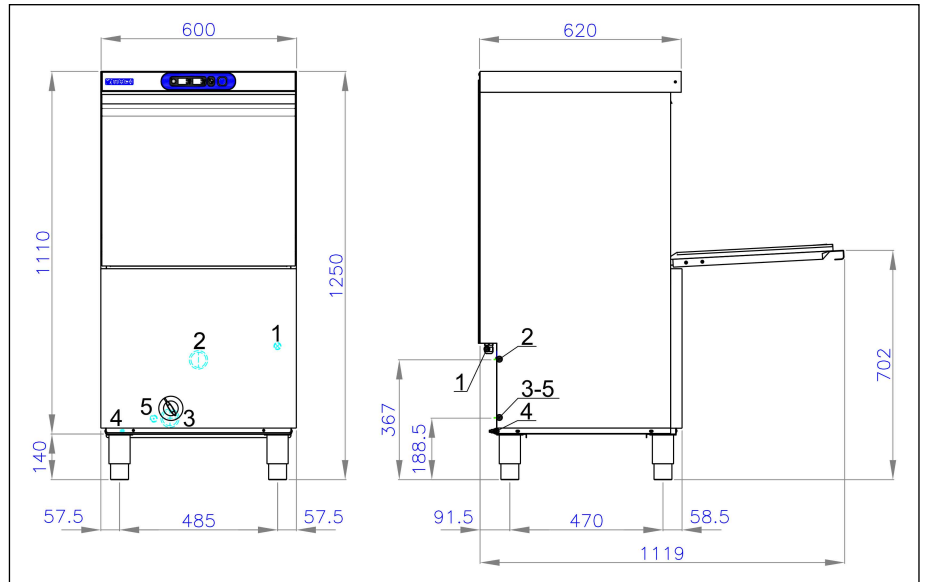

- | | |
|--|-------------------------------|
| 1. Power cable entry 5x2,5 (400Vx3N/
230Vx3N/230Vx1-50Hz) | 3. Water loading pipe Ø3/4" G |
| 2. Water drain pipe Ø30 Hmax=33cm | 4. Equipotential |
| | 5. Dosing pumps entry |

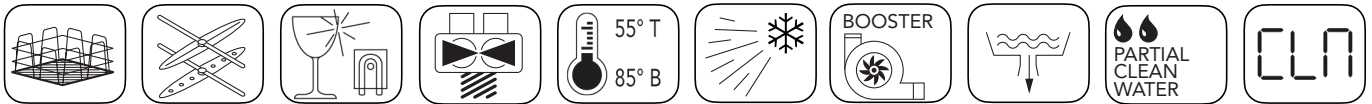

- Double wall.
- Tank with rounded corners.
- Full-width wash tank filters.
- TOUCH control panel with 5 preset wash cycle times.
- Magnetic microswitch to cut out operation of the appliance when door is opened.
- Useful washing height 41 cm, 53x37 cm tray.
- Square basket 50x50 cm. (supplied with 1 plate basket, 1 flat basket, 2 cutlery holders).
- Independent lower/upper washing and rinsing arms.
- Timed manual cold rinse.
- Washing cycle time 90-120-150-180-210 seconds (capacity 306-720 pz/h).
- Displays show the boiler and tank temperature.
- Countdown of the washing cycle underway in minutes and seconds.
- Standard built-in rinse-aid pump.
- Self-cleaning cycle (CLN).
- Booster pump and built-in insulated atmospheric rinse tank made in AISI 304L stainless steel.
- Boiler and tank heating through thermostatically protected armoured heating elements (in exchange).
- Included drain pump.
- Partial water change each cycle - automatic drain of approx. 3,5 litres of (dirty) water between wash and rinse phase.
- Tank capacity lt. 16 and boiler capacity lt. 8.
- Water consumption per cycle lt. 3,5 - Water pressure input ATE 1,5-3,0 - Max temperature of inlet water 50°C.
- Tank heating element kW 2,5 - Boiler heating element kW 6,0 (Cold water input kW 9,0).
- Washing pump power Hp 1.
- Booster pump power kW 0,30.
- Noise level at 1 mt. < 70 dbA.
- Total power kW 6,74.

Note